

# 8077 Exposed

## Shackle Padlock

- 8077 — Green Dial
- 8077A — Green Dial
- 8077AB — Green Dial
- 8077AC — Black Dial
- 8077AD — Black Dial

### Warranty

This lock is guaranteed to be free of defects in materials and workmanship for a period of one year.

We will repair or replace, at our option, any lock which proves to be defective within the one year warranty period, providing it is returned to our factory, Contact S&G for a Return Goods Authorization (RGA) or technical assistance at 859-885-9411, or FAX S&G at 800-634-4843.



**SARGENT AND GREENLEAF**

All new 8077 locks are shipped from the factory set to a single combination number of 25. A new combination should be set before the lock is used.

Before attempting to operate the lock, study the illustrations and familiarize yourself with the names of the various parts of the padlock. Before attempting to change the combination, you should be thoroughly familiar with the opening procedure.

When opening the lock or changing the combination, care should be taken to very precisely align the numbers of the combination and the index. Failure to do this could cause difficulties in opening the lock.

For additional dialing tips, visit S&G's website, at:

[www.sargentandgreenleaf.com](http://www.sargentandgreenleaf.com)

Look for "8077 Dialing Tips" in the Support section.

### OPENING PROCEDURE

1. If the lock is set to the factory shipping combination, use this procedure:

- A. If the lock is new and is just being put into service, its combination is set to the single number 25.
- B. Turn the dial counterclockwise four complete revolutions. On the fourth revolution, align the number 25 on the dial with the padlock's opening index. See Figure A.
- C. Turn the dial clockwise to align zero with the padlock's opening index.
- D. Pull sharply on the shackle to open the lock.

**Note:** If the lock fails to open, dial  $\frac{1}{2}$  number lower or higher to compensate for possible variation of the factory setting. For instance, you should try dialing to  $24\frac{1}{2}$  or  $25\frac{1}{2}$ .

2. If the lock is set to a true, three number combination, use this procedure:

- A. Turn the dial left (counterclockwise) until the first number of the combination aligns with the opening index the fourth time.
- B. Turn the dial right (clockwise) until the second number of the combination aligns with the opening index the third time.
- C. Turn the dial left until the third number of the combination aligns with the opening index the second time.
- D. Turn the dial right until zero is aligned with the opening index the first time.
- E. Pull sharply on the shackle to open the lock.

**Important:** After re-locking the padlock, the dial must be turned at least five complete revolutions in either direction to ensure the mechanism is fully locked.

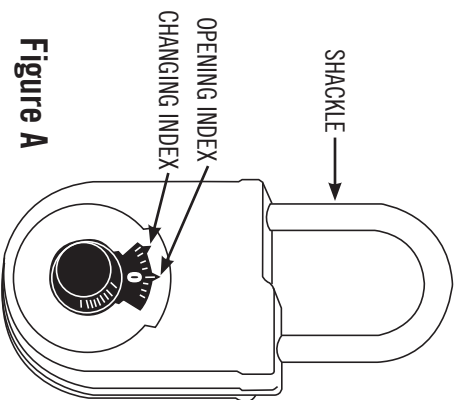

**Figure A**

## CHANGING PROCEDURE

1. Using the existing combination, open the lock as described in the **OPENING PROCEDURE**.
2. Use the screwdriver end of the change key (Figure B) to turn the cover locking screw (Figure C) clockwise until it comes to a complete stop.
3. Remove the padlock's rear cover plate by sliding it upward.

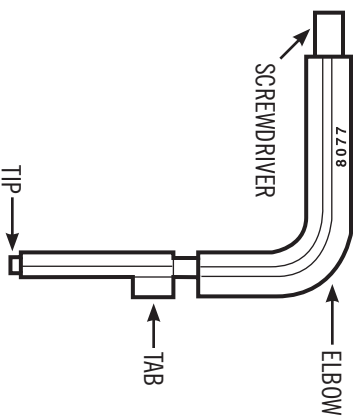

**Figure B**

4. Turn the padlock's cover locking screw counterclockwise, backing it out of the lock body as far as possible. It does not have a positive stop.
5. Close the shackle.
6. Cover the opening index mark with a small piece of tape or your thumb to prevent the possibility of dialing the numbers to the opening index.
7. Dial the existing combination to the changing index. All numbers of the combination, including the last turn to zero, are used in the combination changing procedure.

- A. If the lock is new and just being put into service, the single number 25 is the combination. Turn the dial left (counterclockwise) until 25 aligns with the changing index the fourth time. Turn the dial right (clockwise) one-half revolution, stopping when zero is aligned with the changing index the first time. Do not pull on the shackle.

- B. If the lock is set on any other combination, use the same procedure given for opening the lock, but dial the numbers to the changing index.

8. Use the elbow of the change key (Figure B) to turn the key hole screw on the back of the lock (Figure C) clockwise to the open position. If it will not turn, repeat the procedure in step 7.

9. Insert the change key (tip first) into the change key hole in the back of the lock. The change key is properly seated when the tab on the key is fully inside the lock. Turn the key clockwise one-quarter turn.

10. Set the new combination as follows:

- A. Turn the dial left until the first number of the new combination aligns with the changing index the fourth time.

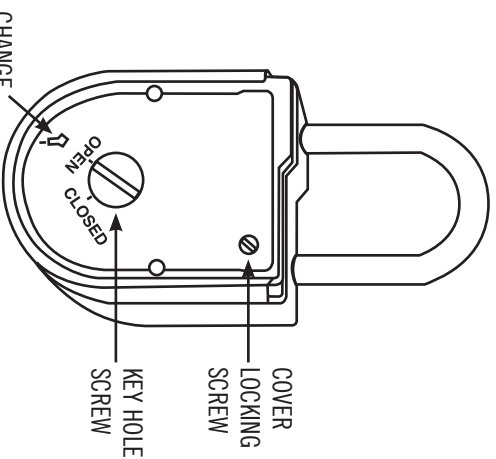

**Figure C**

- B. Turn the dial right until the second number of the new combination aligns with the changing index the third time.

- C. Turn the dial left until the third number of the new combination aligns with the changing index the second time.

- D. Turn the dial clockwise until zero aligns with the changing index the first time.

11. Once the new combination is set and zero is aligned with the changing index, turn the change key counterclockwise one-quarter turn and remove. Do not turn the key hole screw at this time.

## Note:

To ensure you have correctly set the combination, you should once again completely re-dial the new combination as directed in Step 10. Re-insert the change key fully into the lock, but do not turn it. If the key will fully insert, you have set the new combination correctly.

12. Remove the change key and again dial the new combination (including the final turn to zero) to the changing index. Using the change key elbow, turn the key hole screw to the closed position, and close the shackle.

13. If the key hole screw will not return to the closed position, the combination has been incorrectly dialed. Re-dial the combination to the changing index and try again.

14. Remove the tape or your thumb from the opening index. Dial the new combination to the opening index following the steps in the **OPENING PROCEDURE**, and pull sharply on the shackle to open the lock.

15. Turn the cover locking screw clockwise until it comes to a complete stop.

16. Slide the rear cover into place.

17. Turn the lock's cover locking screw counterclockwise as far as possible. Close the shackle.

18. After any combination change, it is advisable to operate the lock at least three times before putting it into service.



# SERVICE PROCEDURE

ISSUE DATE : June 1, 1992

## 8077 PADLOCK COMBINATION RECOVERY

A lost combination for an 8077 padlock can be recovered if the following conditions exist:

1. The cover is removed from the padlock.
2. The shutter control screw is rotated so the change key hole is open and not blocked by the change key hole shutter (see Figure 1).

If either of these two conditions is not met, the lock should be discarded and replaced with a new 8077. Combination recovery techniques which involve drilling holes or removing the inside cover are not acceptable. The 8077 is designed to show evidence of forced entry, so any procedure which leaves marks or holes – even though they may be repaired – is not allowed. Repair parts are not available from S&G for any version of the 8077 padlock.

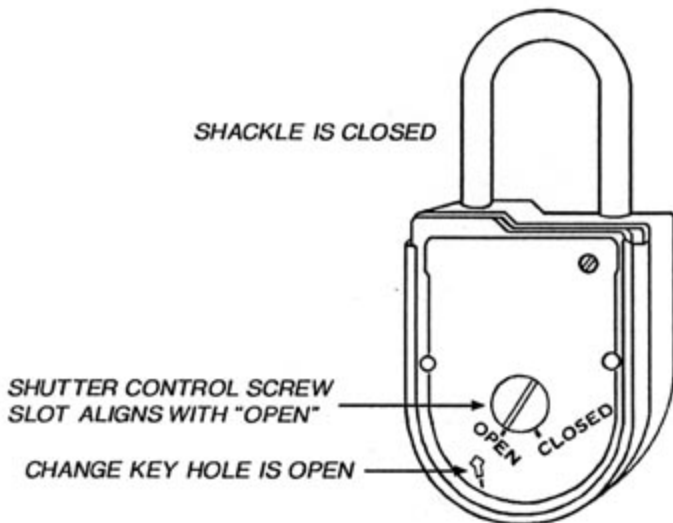

Figure 1

A standard 8077 change key and a special reset key (Figure 2) are required to perform the combination recovery procedure.

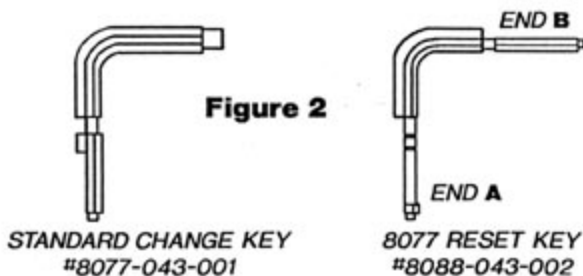

Figure 2

## PROCEDURE

- Step 1 – Insert end **A** of the reset key through the change key hole, and keep the tip of the key in contact with the #3 wheel as you slowly rotate the padlock dial counterclockwise.

- Step 2 – When the change key opening in the wheel passes underneath the tip of the reset key, the key will move into the lock until the first depth mark is just barely outside the lock body (Figure 3).

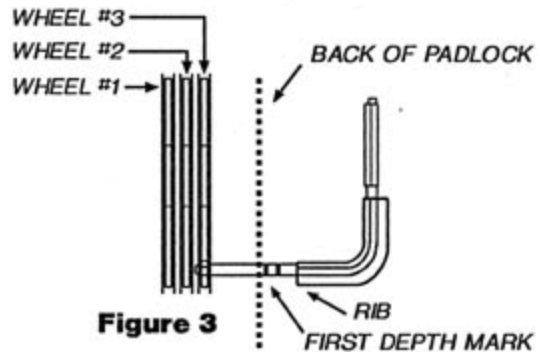

Figure 3

- Step 3 – Turn the reset key clockwise ninety degrees. You should feel a slight release of tension in the wheel mechanism. Again rotate the padlock dial clockwise.

Note: If the dial will not move more than a number or two, the tip of the reset key is not in the change key opening of the wheel. If this happens, pull the key out of the lock just until you can move the dial counterclockwise, then apply light inward pressure on the key as you continue to rotate the dial counterclockwise. Pick up the procedure at Step 2.

- Step 4 – When the change key opening in the #2 wheel passes underneath the tip of the change key, the key will move into the lock until the second depth mark is just barely outside the lock body.

- Step 5 – Turn the reset key clockwise ninety degrees. You should feel a slight release of tension in the wheel mechanism. Again rotate the padlock dial counterclockwise.

Note: If the dial will not move more than a number or two, the tip of the reset key is not in the change key opening of the 2 wheel. If this happens, pull the key out of the lock just far enough to allow you to rotate the dial counterclockwise. Pick up the procedure at Step 4.

(continued on the reverse side)

### Sargent & Greenleaf

One Security Drive, Nicholasville, Kentucky 40356

(606) 885-9411 FAX (606) 885-3063

- Step 6 – When the change key opening in the #1 wheel passes underneath the tip of the change key, the key will move into the lock until the change key rib is just barely outside the lock body.

- Step 7 – Turn the reset key clockwise ninety degrees. You should feel a slight release of tension in the wheel mechanism. Again rotate the padlock dial counterclockwise.

**Note:** If the dial will not move more than a number or two, the tip of the reset key is not in the change key opening of the 1 wheel. If this happens, pull the key out of the lock just far enough to allow you to rotate the dial counterclockwise. Pick up the procedure at Step 6.

- Step 8 – Carefully remove the reset key from the padlock. It may be necessary to wiggle the key slightly to withdraw it. Avoid moving the dial during this step.

- Step 9 – Insert end **B** of the reset key (Figure 4) through the padlock's change key hole until the rib of the key is just outside the padlock (Figure 5). It may be necessary to wiggle the key slightly to insert it fully into the lock.

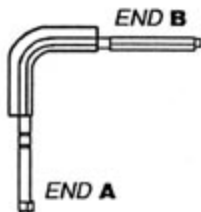

8077 RESET KEY  
#8088-043-002

**Figure 4**

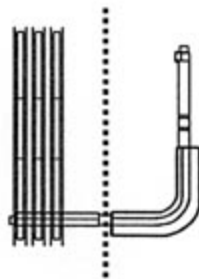

**Figure 5**

- Step 10 – With the reset key in the padlock, turn the dial left (counterclockwise) until "25" aligns with the **changing index** (Figure 7) the fourth time.

- Step 11 – Turn the change key ninety degrees counterclockwise, and pull it straight out of the padlock. Do not turn the key as it is being withdrawn, and make sure the dial does not move off "25." As soon as the reset key is withdrawn, insert the standard change key (tip first) into the padlock's change key hole. The standard change key is properly seated when the tab on the key is fully inside the lock (Figure 6). Turn the key clockwise one-quarter turn.

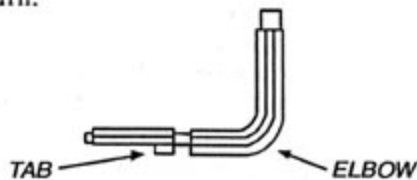

STANDARD CHANGE KEY  
#8077-043-001

**Figure 6**

- Step 12 – Set the new combination as follows:

- A. Turn the dial left until the first number of the new combination aligns with the **changing index** the fourth time.

- B. Turn the dial right until the second number of the new combination aligns with the **changing index** the third time.

- C. Turn the dial left until the third number of the new combination aligns with the **changing index** the second time.

- D. Turn the dial clockwise until zero aligns with the **changing index** the first time.

- Step 13 – Once the new combination is set and zero is aligned with the changing index, turn the change key counterclockwise ninety degrees and remove. Do not turn the shutter control screw.

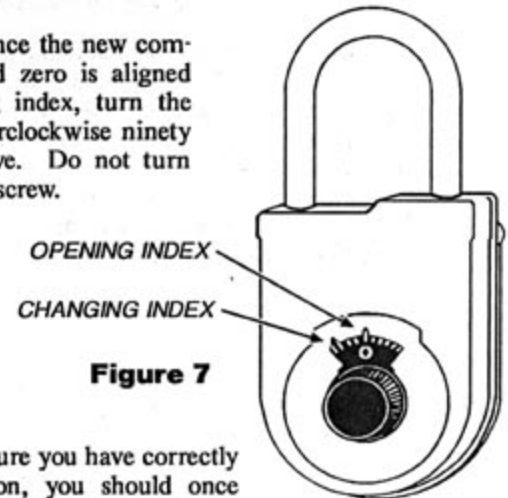

**Figure 7**

**NOTE:** To insure you have correctly set the combination, you should once again completely redial the new combination as directed in Step 12. Re-insert the change key fully into the lock, but do not turn. If the key will fully insert, it simply means you have set the combination correctly.

- Step 14 – Remove the change key and again dial the new combination (including the final turn right to zero) to the changing index. Using the change key elbow, turn the shutter control screw to the closed position.

- Step 15 – If the shutter control screw will not return to the closed position, the combination has been incorrectly dialed. Redial the combination to the changing index and try again.

- Step 16 – Dial the new combination to the opening index following the steps under **OPENING PROCEDURE** in the standard 8077 PADLOCK OPERATING INSTRUCTIONS (document 630-159), and pull on the shackle sharply to open the lock.

- Step 17 – Turn the cover locking screw clockwise until it comes to a complete stop.

- Step 18 – Slide the rear cover into place.

- Step 19 – Turn the cover locking screw counterclockwise as far as possible. Close the shackle.

- Step 20 – After any combination number change, it is advisable to operate the lock at least three times before putting it into use.

## Sargent & Greenleaf

One Security Drive, Nicholasville, Kentucky 40356

(606) 885-9411 FAX (606) 885-3063